

AMS SYSTEM

ODOR COUNTERACTANT DELIVERY EQUIPMENT

- Economical and dependable
- Attractive integrated controller design
- Weather and corrosion resistant
- 1/3 HP 60 GPH pump
- Tamper Proof - Lockable cabinet



The AirStreme AMS is one of the industries most advanced mid-pressure misting systems. AMS provides enhanced programming capabilities, excellent reliability and attractive design all at an affordable price.

The AMS has been designed and manufactured by Ecolo to deliver the industries most advanced, most reliable odor control misting system at an extremely affordable price.

Features of the AMS System

- Integrated Controller Design - pump and programmable controller in one clean polished system
- Surge protection
- Advanced Programming Capabilities - Event Timer, Repeat Cycle, Everyday, Individual Day, Weekday/Weekend
- Digital Display with Touch Pad Programming and Indicator Lights for Accessories - Rain, Wind, Tank Level, Auto Run, Alarm Pump, Tank Mixer
- Adaptive Microprocessor with Real Time Clock
- Internal Battery back up
- Password protection
- Data Collection Capabilities: Runtime, Pump Hours, Daily Peak Temperature, Daily Peak Current

Standard Install Configuration

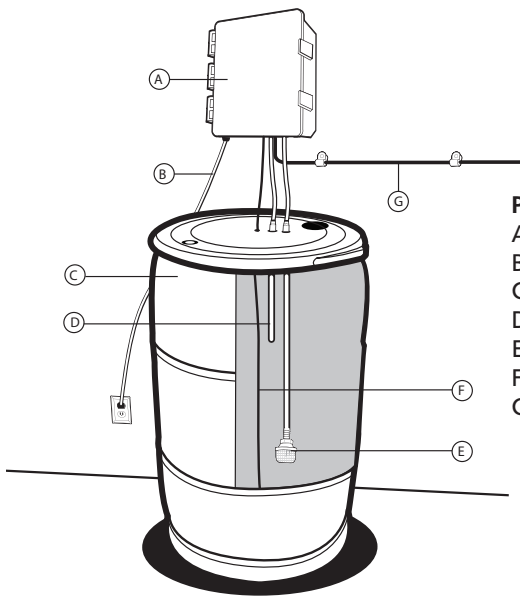

PART	DESCRIPTION
A	AMS Controller
B	Power Cord
C	55 Gallon Drum
D	Return Line
E	Strainer
F	Tank Level Sensor
G	Discharge Line



Ideal For:

- | | |
|------------------|----------------------|
| Trash Rooms | Transfer Stations |
| Composting | Recycling Facilities |
| Wastewater | Farms |
| Food Processing | Loading Docks |
| Shopping Centers | Factories |

Optional Accessories for the AMS:



Rain Sensor

Wind Sensor

Product Specifications

- Dimensions: 14.5" x 13.5" x 7.3"
- Weight: 29 lbs
- Composition: Thermoplastic Polycarbonate
- Electrical: 120V 60hz / 220V 50hz
- 1/3 HP motor
- 60 GPH Pump
- Operates up to 50 nozzles